

### System Overview

The TMM4200/420 is a high-speed, multi-pin marking system that permanently prints messages into a variety of materials such as steel, aluminum, and plastic. Hardened pins are pneumatically accelerated to indent dot matrix characters into the item being marked. The shape, size, density, and location of characters are determined by the user through the system software. The marking head moves the pin cartridge through X- and Y-axis motions to reach the correct position for each dot of the characters to be marked. The system software automatically controls pneumatic pin extension and retraction to mark the message.

The **TMM4200 Marking Head** includes the mechanical motion components to position the marking pins at precise X/Y positions and the pneumatic components to drive the marking pins from, and return the pins to, the pin cartridge. A **shield plate** around the pin cartridge assembly helps prevent debris from entering the marking head cavity.

The TMM4200 marking head is an X/Y-traversing mechanism. Using two stepper motor drives, it accurately positions the pin cartridge at coordinate-defined locations in marking window within .008mm (in Fine mode) and .032mm (in Standard mode). The TMM4200 uses a rack-and-pinion drive system to rapidly position the pin cartridge and to accommodate the rigorous dynamics of impacting and rebounding.

The floating pin design permits consistent, high-quality marks, even on irregular, slightly curved surfaces. It also accommodates applications where marking surfaces cannot be positioned at a consistent distance from the marker.

**TMM4200 Configurations** include a hand-held version and a fixture-mounted version. The hand-held marker is available for portable operation. It incorporates a pistol grip handle with a push

button trigger switch and an integral standoff to position the marker against the marking surface. The fixture-mounted unit is available for mounting in a fixed location.

**Pin Cartridges.** The standard system uses non-lubricated, lightweight pin cartridges for the 25S-series and 150SA-series pins. Cartridges for 25S pins are available in two configurations: four (4) pins spaced on 6mm centers or on 12mm centers. The cartridge for 150SA pins contain two (2) pins spaced on 25mm centers. The cartridge configuration dictates the size of the marking window along the X-axis. Refer to the marking head installation drawing for details.

**Marking Pins.** The TMM4200 uses 25S-series and 150SA-series marking pins available in various cone (tip) angles. The 25S-series pins are made of powdered steel or carbide. The 150SA pins are made of powdered steel with carbide tips. Refer to the marking head installation drawing for pin stroke (pin extension) dimensions.

The **Marker Cable** connects the marking head to the controller. The highly flexible cable is 4m (13.1 ft.) long and attaches to the back of the marker with a quick disconnect connector. Optional extension cables lengths are available.

The **Filter/Regulator Unit** includes two regulators with pressure gauges to control drive air and return air. The first regulator contains a filter to help remove contaminants from the supply air. Two air lines connect the regulated air to the marking head. Drive air fires the impact pin; return air pushes it back into the cartridge. Standard air lines are 4m (13.1 ft.) long made of 6mm tubing.

**TMC420 Controller** includes an integrated keyboard with a four line LCD display. It provides the electrical interface and software control of the TMM4200 marking head. (Refer to *TMC420 Controller Specifications* for details.)

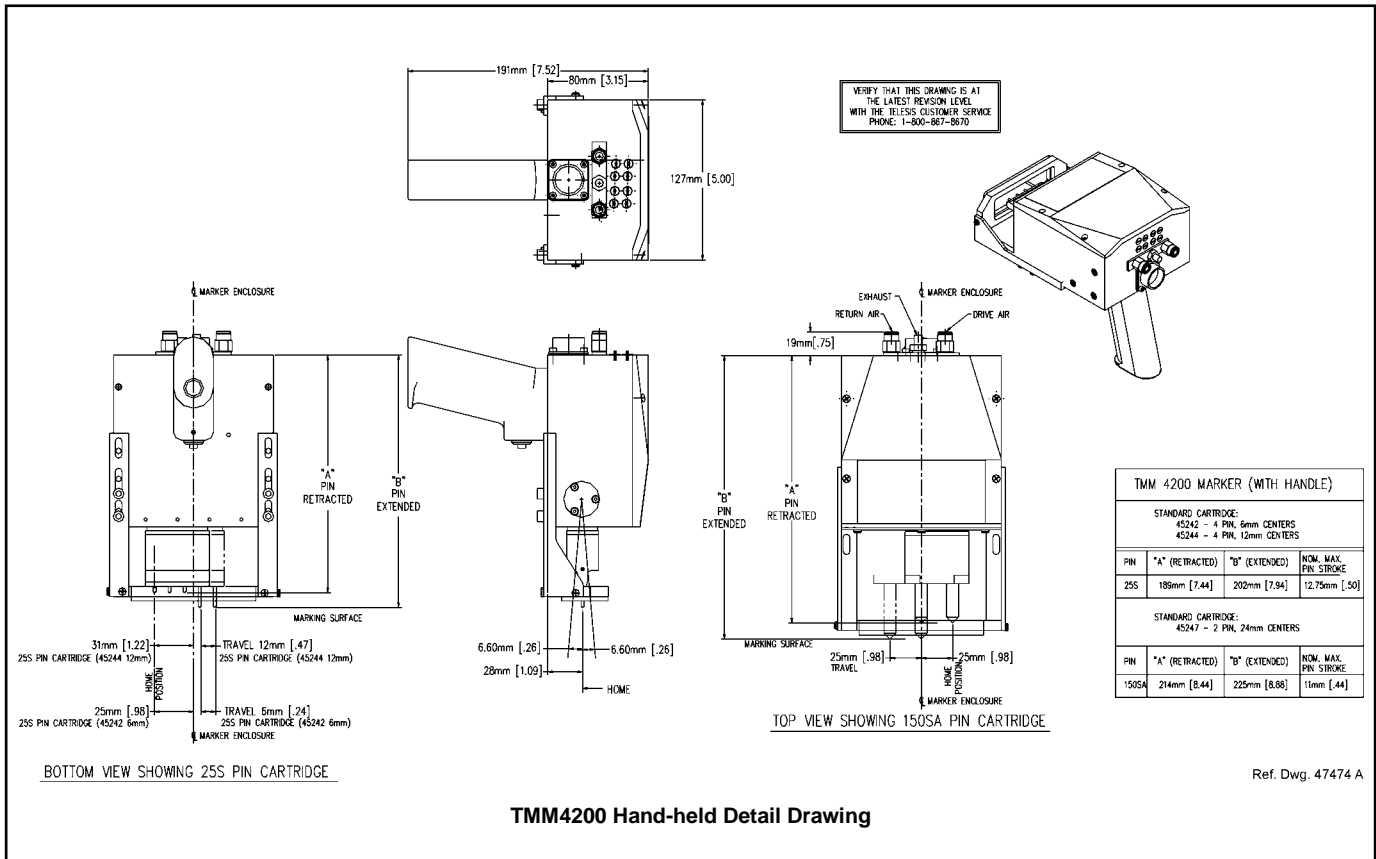

## System Setup

- Fixture-mounted markers only.** When designing a fixture, allow for 3-axis adjustment to aid in horizontal, vertical, and lateral alignment of the marking head.  
Mount marking head to a suitable fixture using four M5-0.80 bolts. **Mounting bolts must not extend into marking head more than 10mm (0.39 in.).**
- Mount filter/regulator assembly, using brackets provided, within 4m (13.1 ft.) of marking head.
- Connect drive air and return air lines to the connectors on back of marking head.
- Connect supply air to input port on filter/regulator assembly.
- Adjust drive air and return air for proper pin impact depth.
  - Nominal drive air pressure 5.5 bars (80 psi)
  - Nominal return air pressure 1.5 bars (20 psi)
- Adjust pin stroke for proper pin impact depth.

- Locate controller as close as practical to marking head. Standard marker cable length is 4m (13.1 ft.).  
**Note: The TMC420 is not a sealed unit. Protect it from potentially damaging conditions; do not block case vents.**
- Ensure controller power switch (on back panel) is OFF; connect power cable to controller.
- Connect marker cable to controller; tighten securely.
- Position controller power switch to ON (on back panel) to start the system software.

## System Options

- Optional Custom Cartridges (pin quantity and spacing)
- Marking Head Extension Cables
- TMC420 Controller Mounting Bracket Kit
- Bar Code Scanner
- Bar Code Wand
- Backup Utility Software
- Upgrade Utility Software
- Logo/Font Generator Software

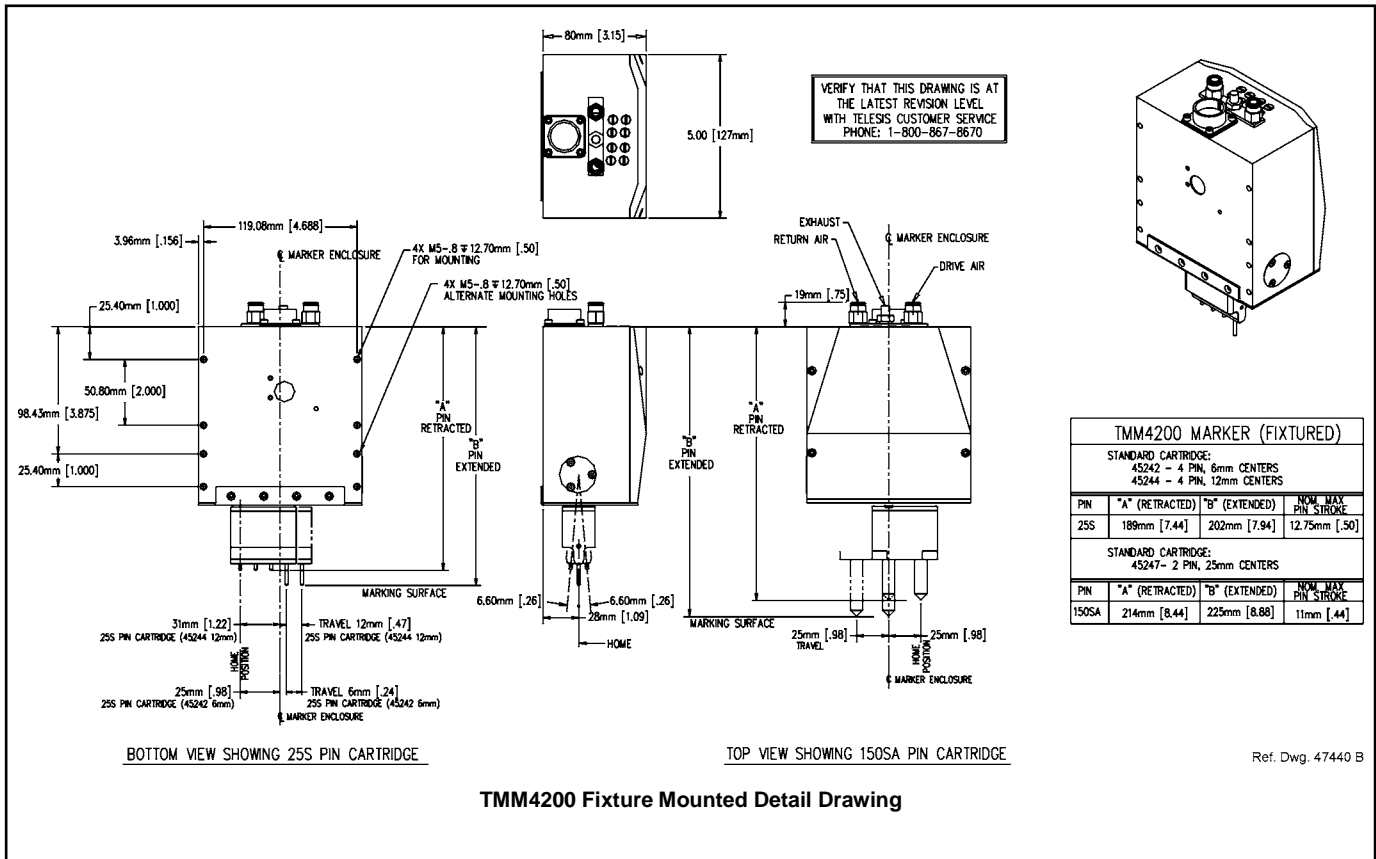

**TMM4200 Marking Head Specifications**

- DIMENSIONS**     *see illustrations*
- RATING**            NEMA 2 (I.P. 41)
- WEIGHT**            **HAND-HELD:** 2.06 kg (4.54 lb)  
                          excluding marker cable, and pin cartridge  
                          **FIXTURED:** 1.59 kg (3.50 lb)  
                          excluding marker cable, pin cartridge, handle,  
                          standoff, and tooling
- OPERATING TEMP.** 0° to 50°C (32° to 122° F), non-condensing
- AIR SUPPLY**        Clean and dry, 4.2 to 8.3 bars (60 to 120 psi)
- AIR CONSUMPTION** 0.15 L/sec (0.32 SCFM) idle  
                          0.28 L/sec (0.60 SCFM) marking
- MARKING AREA**    *see illustrations*
- PIN TYPES**         25S-series, various cone (tip) angles  
                          150SA-series, various cone (tip) angles
- PIN MATERIAL**    Powdered Steel or Carbide (25S-series)  
                          Powdered Steel w/ Carbide Tip (150SA-series)

**Marking Characteristics.** The TMM4200 can produce characters as small as 0.75mm (0.03 in.) high. Text strings may be rotated 180° to print inverted. Characters can be printed with resolutions from 4 to 79 dots/cm (10 to 200 dots/in.) for an engraved look. The depth of mark can be adjusted over a significant range by adjusting the pin stroke and, to a lesser extent, by adjusting the drive air pressure.

Three marking modes are available to optimize quality and speed. Raster mode prints side-to-side, indexing downward one row at a time. Matrix mode prints up and down, indexing one column at a time. Continuous mode prints with only one pin at a time tracing the character shape.

**Marking Speeds.** The system is capable of marking eight (8) characters per second (two characters per pin per second) using a four-pin cartridge to print 3mm (0.118 in.) high characters in the 5x7 font. Speeds will vary widely depending on the selected character size, style, and dot density. Specific times can be verified by a Telesis representative.

**Marking Noise.** Although every attempt is made to reduce noise, the material being marked significantly influences the noise level. For example, marking a solid lead block produces less noise than marking a thin-walled steel pipe.

**Pin Life.** Pin life depends largely on the type of material being marked, how hard or abrasive it is, and the required marking depth. On typical metals with a hardness of Rockwell Rb47, marking at a depth of .127mm (0.005 in.), powdered steel pins average about 3 million impressions before needing sharpened.

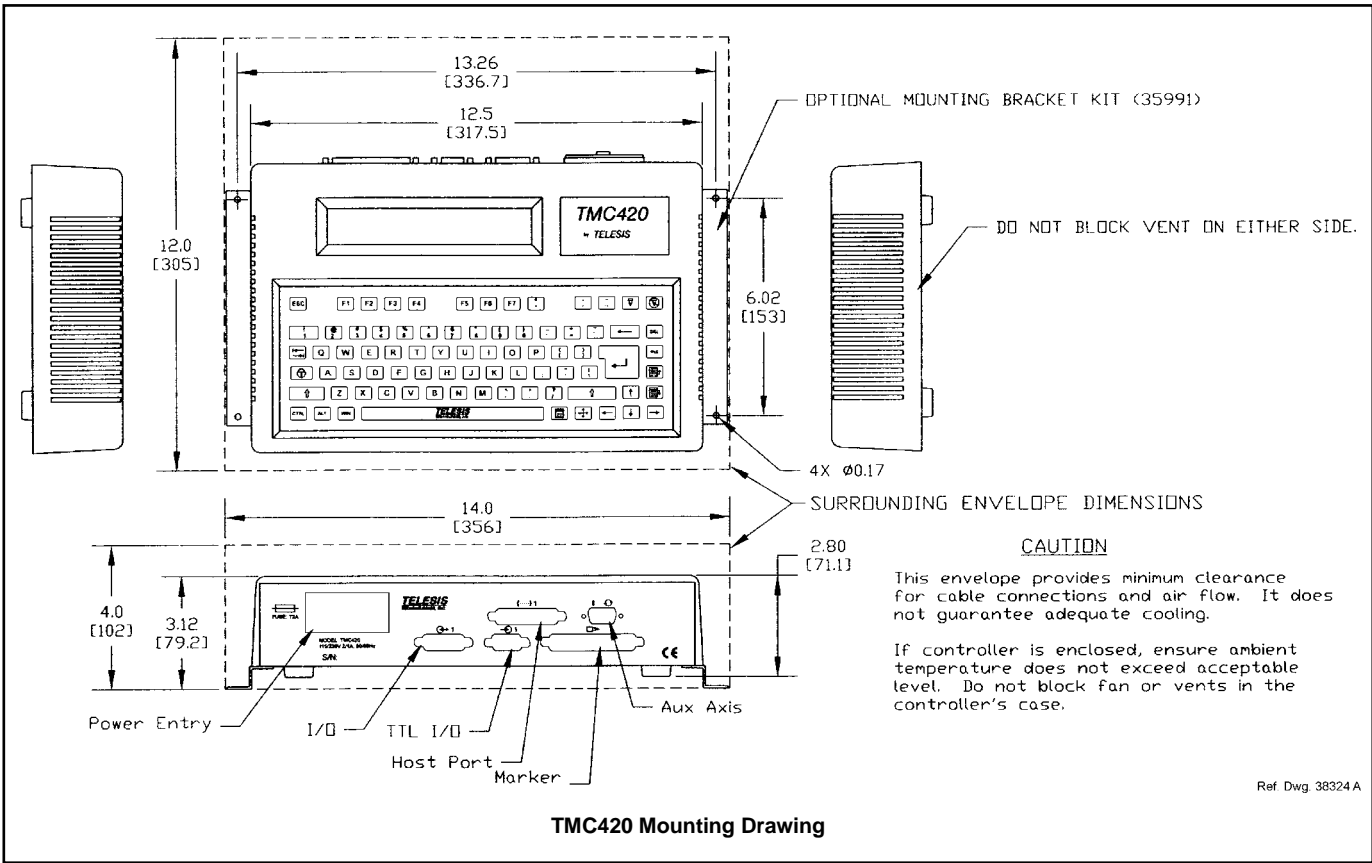

TMC420 Mounting Drawing

**TMC420 Controller**

**Configurations.** Three models of the TMC420 are available for use with the TMM4200: the TMC420 table-top controller, the TMC420P panel-mounted controller, and the TMC420N enclosure-mounted controller. All controllers provide the same software features and the same connectivity for external communications. Differences occur only in their mounting configurations.

**TMC420 Specifications**

<b>DIMENSIONS</b>	<i>refer to TMC420 Mounting Drawing</i>
<b>RATING</b>	NEMA 1 (I.P. 30)
<b>WEIGHT</b>	2.15 kg (4.75 lb.)
<b>OPERATING TEMP.</b>	0° to 50°C (32° to 122° F), non-condensing
<b>POWER</b>	95-130 VAC, 2 amps, 50-60 Hz single phase 200-250 VAC, 1 amp, 50-60 Hz single phase
<b>I/O VOLTAGE</b>	12 to 24 VDC (customer-supplied)

**TMC420P Specifications**

<b>DIMENSIONS</b>	<i>refer to TMC420P Mounting Drawing</i>
<b>RATING</b>	NEMA 1 (I.P. 30) stand-alone NEMA 12 (I.P. 65) installed
<b>WEIGHT</b>	3.10 kg (6.8 lb.)
<b>OPERATING TEMP.</b>	0° to 50°C (32° to 122° F), non-condensing
<b>POWER</b>	95-130 VAC, 2 amps, 50-60 Hz single phase 200-250 VAC, 1 amp, 50-60 Hz single phase
<b>I/O VOLTAGE</b>	12 to 24 VDC (customer-supplied)

**TMC420N Specifications**

<b>DIMENSIONS</b>	<i>refer to TMC420N Mounting Drawing</i>
<b>RATING</b>	NEMA 12 (I.P. 65)
<b>WEIGHT</b>	12.77 kg (28.1 lb.)
<b>OPERATING TEMP.</b>	0° to 50°C (32° to 122° F), non-condensing
<b>POWER</b>	95-130 VAC, 2 amps, 50-60 Hz single phase 200-250 VAC, 1 amp, 50-60 Hz single phase
<b>I/O VOLTAGE</b>	12 to 24 VDC (customer-supplied)

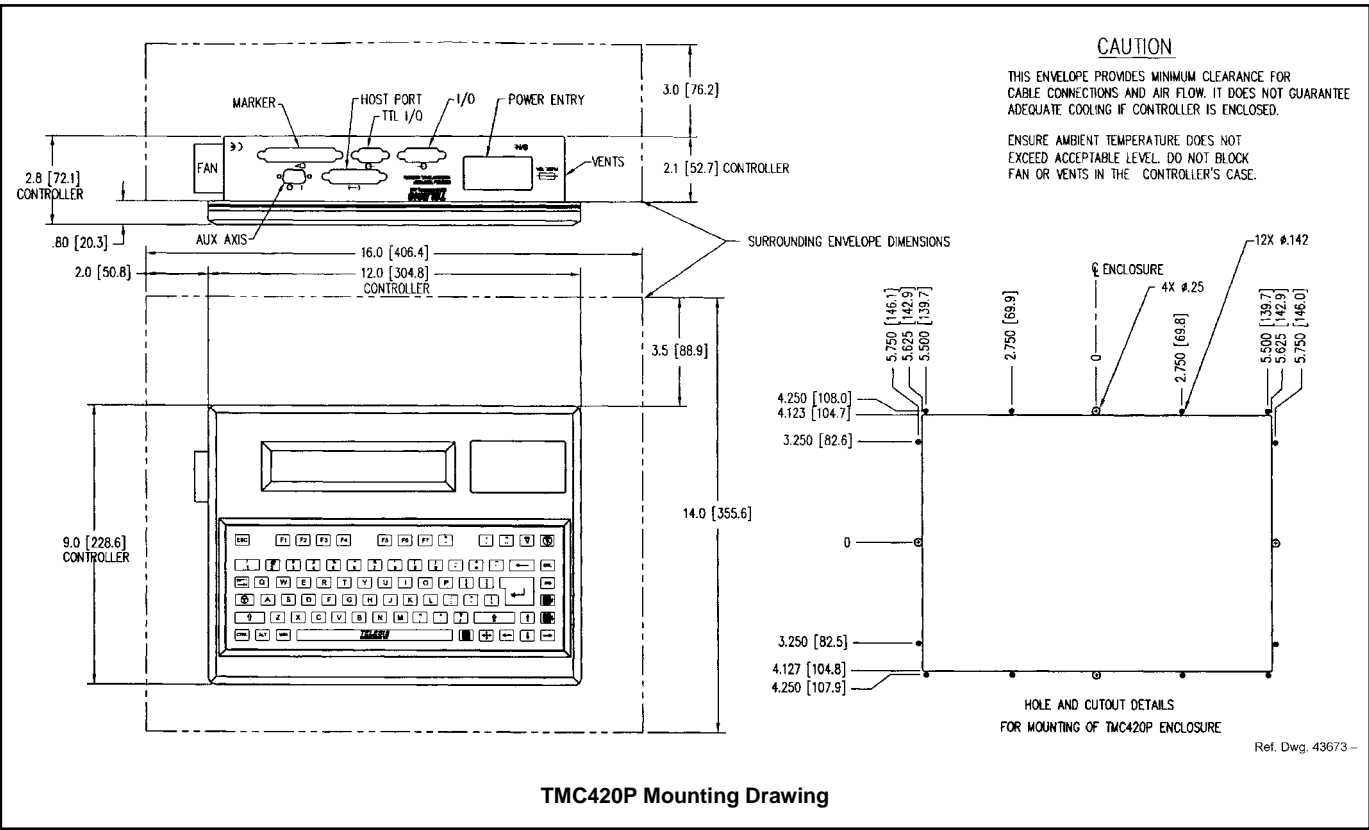

TMC420P Mounting Drawing

**Interface Panel.** The interface panel provides various ports for connecting the marker, host computers, logic controllers, or optional accessories.

**System Software.** The system software is permanently installed in the controller. It provides the user interface for the operator to control the marker. The software also provides a library for storing, loading, and editing user-defined patterns. Patterns are files stored in the controller's memory. The controller can store up to 75 patterns. Each pattern contains one or more fields. A field defines a single object and how it will be printed. Fields may define text strings, 2D data matrix symbols, Goto commands, or Pause commands. Text fields may include alphanumeric characters, symbols, and special message flags. The message flags automatically insert data into the text string, such as serial numbers, times, and dates.

**I/O Control Signals.** The TMC420 is configured for DC I/O only. The TTL I/O Port may be used to connect a remote pushbutton control for Start Print and Abort commands. The I/O Port may be used to connect a PLC or other DC I/O source. The I/O Port allows remote control of pattern selection, printing, aborting, placing the marker online, and monitoring of the Ready and Done output signals. Cable connectors and connector pins are supplied with the controller for constructing appropriate interface cables.

- START PRINT** Input signal, begins print cycle
- SEL\_0, 1, 2, 3 \*** Input signals, remote pattern selection (15\* max.)
- SEL\_3 \*** Input signal, marker online
- ABORT** Input signal, aborts print cycle
- INPUT COMM** For all inputs (+ or - supply)
- READY** Output signal, ready for message or start print
- DONE** Output signal, print cycle complete
- OUTPUT COMM** For all outputs (+ or - supply)

\* System software allows SEL\_3 signal to be configured for remotely selecting patterns or for remotely placing the marker online. If used for marker online, pattern selection is reduced to 7 patterns (max).

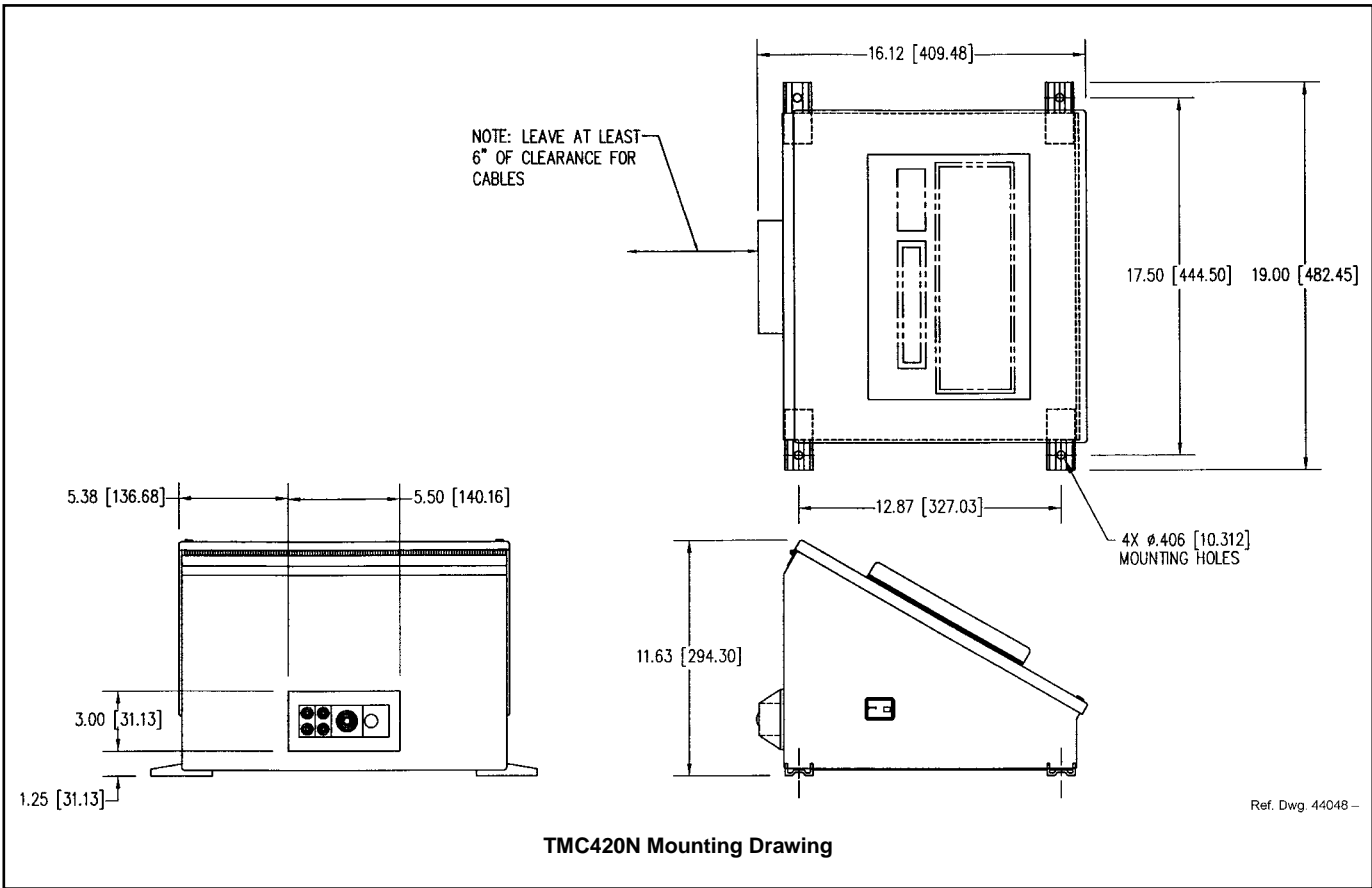

**Serial Interface.** The Host Port is used for RS-232 and RS-485 communications with serial devices such as a host computer or bar code scanner. Up to 31 controllers may be used in a multi-drop configuration using the RS-485 interface. The host computer can load patterns, download messages, place the marker on/offline, and monitor system errors. (See *Serial Communications* for details.)

**Serial Communications.** The Host Port may be used for either RS-232 or RS-485 communication. The RS-232 interface is most often used with remote devices such as bar code readers or host computers. The RS-485 interface is normally used for long transmission distances or multi-drop networks of up to 31 TMC420 controllers. The serial port may be configured to communicate using either the Telesis Programmable Protocol or Telesis Extended Protocol. The following describes the serial data character format on all transmissions to and from the TMC420 controller.

- Asynchronous
- 1200, 2400, 4800, 9600, or 19200 baud-host
- One Start Bit
- One or Two Stop Bit(s)
- Seven or Eight Data Bits
- None, Even or Odd Parity

**Programmable Protocol** is used where very simple one-way communications are required (such as with bar code scanners). Programmable Protocol provides no error checking or acknowledgment of the transmitted data. Note that XON/XOFF Protocol applies even when Programmable Protocol is selected.

**Starting Character** specifies where the software begins to count character positions. This number must be entered in ASCII decimal format such as 2 for STX.

**Terminating Character** identifies the end of transmitted string (usually ASCII carriage return character, decimal 13).

**Character Position** counted from the starting character ignoring all characters preceding it.

**Character Length** accepts variable length messages (if set to 0) or messages of a pre-specified, fixed number of characters.

**Ignore Character** identifies the character to ignore when sent from the host (usually ASCII line feed character, decimal 10)

**Message Type** allows message-type recognition which defines how the marking system will use data it receives from the host..

- P** loads a specific pattern identified by data extracted from host
- V** updates first variable text field with data extracted from host
- 1** overwrites first text field with data extracted from the host
- Q** updates text in first query buffer with data extracted from host
- 0** indicates that host will provide message type, field number (if applicable), and data; delegates message type selection to the host on message-by-message basis. The host message must use the format **Tnn<string>** where:
  - T** = P, V, 1, or Q to indicate the message type.
  - nn** = two-digit number to indicate field number or query text buffer where data will be placed. Note that a number is not used with Message Type P.
  - <string>** = pattern name (Message Type P) or field data (Message Types V, 1, or Q), as applicable.

**Extended Protocol** includes error checking and transmission acknowledgment. It should be used in applications where serial communication is a vital part of the marking operation. Extended Protocol must be used in multi-drop applications. All communications are carried out in a master-slave relationship with the host being the master. Only the master has the ability to initiate communications. If the host does not receive a response within three seconds, it should re-transmit its original message. If no response is received after three tries, it should declare the link to be down.

The following describes the message format as sent from the master to the TMC420 controller.

**SOH TYPE [##] STX [DATA TEXT] ETX BCC CR**

**SOH** ASCII Start of Header character (001H). The controller ignores all characters received prior to the SOH.

**TYPE** A single, printable ASCII character that defines the meaning (type) and content of the message downloaded from the host, where:

- 1** overwrites the specified field of currently loaded pattern, using the format **1nn<string>** where nn is the field number.
- V** updates specified variable text field of currently loaded pattern, using the format **Vnn<string>** where nn is the field number.
- Q** updates specified query buffer with the data received from host, using the format **Qnn<string>** where nn is the buffer number.
- P** specifies pattern name to be loaded for printing
- O** resets marker and places it online
- G** initiates a print cycle to mark the currently loaded pattern
- I** requests the marker output status; returns a single-digit hexadecimal value to report state of READY and DONE:

Returned Value	DONE	READY
0	off	Off
1	off	ON
2	ON	Off
3	ON	ON

- S** requests the marker error status; returns a value that represents a particular type of error:

Returned Value	TYPE OF ERROR
0x0000	(no error)
0x0001	ONLINE_ERROR
0x0002	PATTERN_LOAD_ERROR
0x0004	DISALLOWED_NO_PATTERN
0x0008	DISALLOWED_OFFLINE
0x0010	PATTERN_FIELD_ERROR
0x0020	MARKER_ABORTED_ERROR
0x0080	PIX_OUT_OF_RANGE_ERROR
0x0100	RAM_ERROR
0x0200	SN_RANGE_ERROR

**[##]** Two optional ASCII decimal digits that specify the Station ID number for use in multi-drop network applications. The ID may range from 00-31. Note that "00" is reserved for applications where only one controller is used. In such applications, this field may be eliminated and "00" will be assumed.

**STX** ASCII Start of Text Character (002H).

**[DATA TEXT]** Optional field that may be required for certain message types.

**ETX** ASCII end of text character (003H).

**BCC** Optional Block Check Code that is generated and sent to improve link reliability by providing fault detection. The BCC is calculated by taking an eight bit addition of the TYPE and DATA TEXT characters and transmitting them as a three digit ASCII decimal number in the range from 000 to 255. If the sum is greater than 255, the most significant bit overflows and is discarded.

**CR** ASCII Carriage Return Character (00DH).