

System Overview

The TMM5100/420 marking system permanently prints messages into a variety of materials such as steel, aluminum, and plastic. Hardened pins are pneumatically accelerated to indent dot matrix characters into the item being marked. The shape, size, density, and location of characters are determined by the user through the system software. The marking head moves the pin cartridge through X- and Y-axis motions to reach the correct position for each dot of the characters to be marked. The system software automatically controls pin extension and retraction to mark the message.

TMM5100 Marking Head includes the mechanical motion components to position the marking pin at precise X/Y positions and the pneumatic components to drive the marking pins from, and return the pins to, the pin cartridge.

The TMM5100 marking head is an X/Y-traversing mechanism. Using two stepper motor drives, it accurately and rapidly positions the pin cartridge at coordinate-defined locations in marking window within .002" (.050 mm). The TMM5100 accommodates the rigorous dynamics of impacting, rebounding, and rapid positioning of the cartridge using a system of belt-driven leadscrews and guide rods.

The floating pin design permits high quality, consistent marks on irregular, slightly curved surfaces. It also accommodates applications where marking surfaces cannot be positioned at a consistent distance from the marker.

Pin Cartridges Aluminum cartridges are used for 25L-series pins; steel cartridges for 101-series pins. Non-lubricated, lightweight plastic pin cartridges are used for 150S-series pins and optionally, as custom cartridges, for 25L- and 101-series pins. Metal cartridges require lubrication via the filter/regulator/lubricator unit. Pin cartridges are available in many configurations based on the number of pins and the pin spacing (.25 to .75 inches) [6 to 19 mm]. Cartridges for 25L-series and 101-series pins typically hold 6 pins. Cartridges for 150S-series pins may contain from 2 to 6 pins. The cartridge configuration dictates the size of the marking window along the X-axis. Refer to the marking head installation drawing for details.

Marking Pins for the TMM5100 include the 25L-, 25XL-, 101-, and 150S-series. Refer to the marking head installation drawing for pin stroke (pin extension) dimensions. Refer to the marking depth tables for pin cone angles and depths.

Marker Cable connects the marker to the controller. The highly flexible, removable cable is 8m (26 ft.) long. Optional extension cables are available for greater distances.

Filter/Regulator/Lubricator Unit includes two regulators with pressure gauges to control the drive air and return air, and an oil reservoir with delivery control. The regulator contains a coarse filter and a coalescing filter to remove finer particles. Two air lines connect the regulated air to the marking head. Drive air fires the impact pin; return air pushes it back into the cartridge and delivers lubricant to the cartridge. Systems with plastic pin cartridges use filter/regulator units without lubricators since oil is not required and will damage the cartridges. Standard air lines are 25 ft. (7.5 m) long made of 3/8" tubing.

TMC420 Controller includes an integrated keyboard with a four line LCD display. It provides the electrical interface and software control of the TMM5100 marking head. (Refer to *TMC420 Controller Specifications* for details.)

System Options

- Mounting Post with Hand Crank; 19.3" (492 mm) Travel
- Cartridge Standoffs (for precise marker positioning)
- Optional, Custom Cartridges
- Pistol Grip Handle with Pushbutton Controls
- Gimbal Assemblies and Cable Balancers
- Marking Head Extension Cables
- TMC420 Controller Mounting Bracket Kit
- Bar Code Scanner or Bar Code Wand with Cable
- Foot Switch (Start Print) or Pushbutton Station (Start/Abort)
- Backup Utility Software
- Upgrade Utility Software
- Logo/Font Generator Software

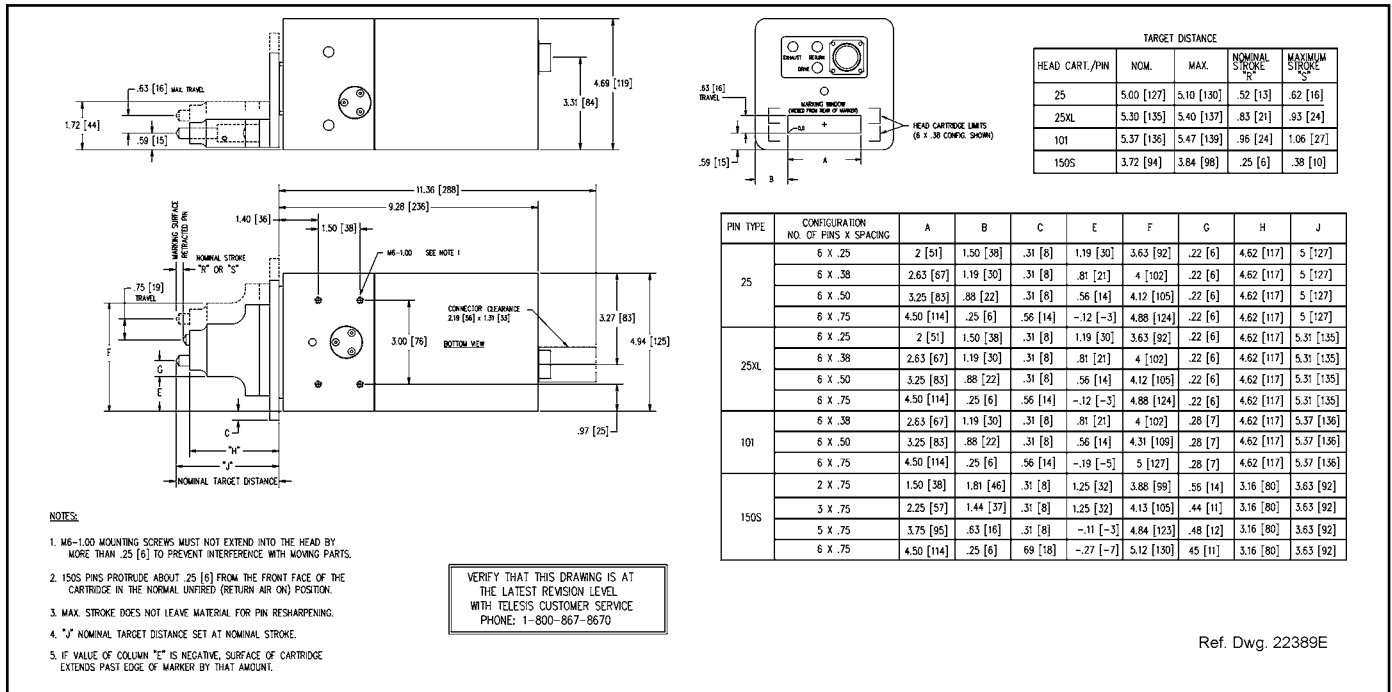

Ref. Dwg. 22389E

System Setup

When designing a fixture, allow for 3-axis adjustment to aid in horizontal, vertical, and lateral alignment of the marking head.

- Mount marking head to a suitable fixture using two M6-1.00 bolts. **Mounting bolts must not extend into marking head more than more 1/4" (6.3 mm).**
- Mount filter/regulator assembly, using brackets provided, within 25 ft. (7.5 m) of marking head; within 15 ft. (4.5 m) if lubricator is used.
- Connect drive air and return air lines to the connectors on back of marking head.
- Connect supply air to input port on filter/regulator assembly.
- Adjust pin stroke, drive air, and return air for proper pin impact depth.
 - Nominal drive air pressure 80 psi (5.5 bars)
 - Nominal return air pressure 20 psi (1.4 bars)
- Locate controller as close as practical to marking head. Standard marker cable length is 8 m (26 ft.).

Note: The TMC420 is not a sealed unit. Protect it from potentially damaging conditions; do not block case vents.

- Ensure controller power switch (on back panel) is OFF; connect power cable to controller.
- Connect marker cable to marking head and to controller; tighten securely.
- Position controller power switch to ON (on back panel) to start the system software.

TMM5100 Marking Head Specifications

DIMENSIONS	<i>see illustration above</i>
WEIGHT	10.8 lb. (4.9 Kg) excluding support tooling
OPERATING TEMP.	32° to 122° F (0° to 50° C), non-condensing
AIR SUPPLY	Clean and dry, 60 to 120 psig (4.2 to 8.3 bars)
AIR CONSUMPTION	1.8 SCFM (idle) 9.0 SCFM (marking)
MARKING AREA	<i>see illustration above</i>
PIN TYPES	25L-, 25XL-, 101-, or 150S-series
PIN MATERIAL	Powdered metal or carbide (25L, 25XL, 101- series) Powdered metal or carbide-tipped (150S-series)

Marking Characteristics. The TMM5100 can produce characters as small as .06" (1.5 mm). Characters can printed with resolutions from 10 dots per inch to 200 dots per inch for an engraved look. The depth of mark can be adjusted over a significant range by adjusting the pin stroke and, to a lesser extent, by adjusting the drive air pressure. Four marking modes are available to optimize quality and speed. Raster mode prints side-to-side, indexing downward one row at a time. Matrix mode prints up and down, indexing one column at a time. Continuous mode prints with only one pin at a time. Segment mode simultaneously prints multiple characters (using multiple pins) in fully formed mode.

Marking Speeds. Generally, the system will mark one character per second per pin (using 5x7 font, .125" [3 mm] high characters). Speeds will vary slightly depending on the selected character size, style, and dot density. Specific times can be verified by a Telesis representative.

Marking Noise. All TMM5100 markers are equipped with mufflers on the solenoid exhaust to reduce noise. Although every attempt is made to reduce noise, the material being marked significantly influences the noise level. For example, marking a solid lead block produces less noise than marking a thin-walled steel pipe.

TMM5100 Marking Head Specifications (continued)

Pin Life. Pin life depends largely on the type of material being marked, how hard or abrasive it is, and the required marking depth. On typical metals with a hardness of Rockwell Rb47, marking at a depth of .005" (.127 mm), powdered steel pins average about 3 million impressions before needing sharpened; carbide pins average approximately 9 million impressions. If carbide pins are used, marking times will increase by approximately 25% due to the increased weight of the pins.

Marking Depth. The following tables provide sample marking depths. Drive air was set at 80 psi (5.5 bars); return air was set at 20 psi (1.4 bars); pin stroke was set to the maximum allowable distance for each pin type to achieve the maximum depth of mark.

Max. Marking Depths – Type 25L Powdered-Metal Pins

MATERIAL (HARDNESS)	22° CONE	30° CONE	45° CONE	60° CONE
Aluminum (Rb2)	.0040 in .1016 mm	.0045 in .1143 mm	.0080 in .2032 mm	.0110 in .2794 mm
Brass (Rb22)	.0025 in .0635 mm	.0030 in .0762 mm	.0055 in .1397 mm	.0080 in .2032 mm
Cast Iron (Rb47)	.0025 in .0635 mm	.0030 in .0762 mm	.0055 in .1397 mm	.0080 in .2032 mm
Cold Rolled Steel (Rb53)	.0025 in .0635 mm	.0030 in .0762 mm	.0055 in .1397 mm	.0080 in .2032 mm

Max. Marking Depths – Type 25L Carbide Pins

MATERIAL (HARDNESS)	22° CONE	30° CONE	45° CONE	60° CONE
Aluminum (Rb2)	.0040 in .1016 mm	.0050 in .1270 mm	.0080 in .2032 mm	.0065 in .1651 mm
Brass (Rb22)	.0025 in .0635 mm	.0035 in .0889 mm	.0060 in .1524 mm	.0040 in .1016 mm
Cast Iron (Rb47)	.0025 in .0635 mm	.0035 in .0889 mm	.0060 in .1524 mm	.0040 in .1016 mm
Cold Rolled Steel (Rb53)	.0025 in .0635 mm	.0035 in .0889 mm	.0060 in .1524 mm	.0040 in .1016 mm

Max. Marking Depths – Type 101 and 150S Pins

MATERIAL (HARDNESS)	30° CONE	45° CONE	45° CONE *	60° CONE
Aluminum (Rb2)	.0110 in .2794 mm	.0150 in .3810 mm	.0170 in .4318 mm	.0220 in .5588 mm
Brass (Rb22)	.0080 in .2032 mm	.0120 in .3048 mm	.0135 in .3429 mm	.0160 in .4064 mm
Cast Iron (Rb47)	.0060 in .1524 mm	.0100 in .2540 mm	.0115 in .2921 mm	.0115 in .2937 mm
Cold Rolled Steel (Rb53)	.0060 in .1524 mm	.0100 in .2540 mm	.0110 in .2794 mm	.0150 in .3810 mm

* Denotes Carbide Pin (all others are powdered metal)

TMC420 Controller

Configurations. Three models of the TMC420 are available for use with the TMM5100: the TMC420 table-top controller, the TMC420P panel-mounted controller, and the TMC420N enclosure-mounted controller. All controllers provide the same software features and the same connectivity for external communications. Differences occur only in their mounting configurations.

TMC420 Specifications:

DIMENSIONS	<i>refer to TMC420 Mounting Drawing</i>
RATING	NEMA 1 (I.P. 30)
WEIGHT	2.15 kg (4.75 lb.)
OPERATING TEMP.	0° to 50°C (32° to 122° F), non-condensing
POWER REQ'MENT	95-130 VAC, 2 amps, 50-60 Hz single phase 200-250 VAC, 1 amp, 50-60 Hz single phase
I/O VOLTAGE	12 to 24 VDC (customer-supplied)

TMC420P Specifications:

DIMENSIONS	<i>refer to TMC420P Mounting Drawing</i>
RATING	NEMA 1 (I.P. 30) stand-alone NEMA 12 (I.P. 65) installed
WEIGHT	3.10 kg (6.8 lb.)
OPERATING TEMP.	0° to 50°C (32° to 122° F), non-condensing
POWER REQ'MENT	95-130 VAC, 2 amps, 50-60 Hz single phase 200-250 VAC, 1 amp, 50-60 Hz single phase
I/O VOLTAGE	12 to 24 VDC (customer-supplied)

TMC420N Specifications:

DIMENSIONS	<i>refer to TMC420N Mounting Drawing</i>
RATING	NEMA 12 (I.P. 65)
WEIGHT	12.77 kg (28.1 lb.)
OPERATING TEMP.	0° to 50°C (32° to 122° F), non-condensing
POWER REQ'MENT	95-130 VAC, 2 amps, 50-60 Hz single phase 200-250 VAC, 1 amp, 50-60 Hz single phase
I/O VOLTAGE	12 to 24 VDC (customer-supplied)

Interface Panel. The interface panel provides various ports for connecting the marker, host computers, logic controllers, or optional accessories.

System Software. The system software is permanently installed in the controller. It provides the user interface for the operator to control the marker. The software also provides a library for storing, loading, and editing user-defined patterns. Patterns are files stored in the controller's memory. The controller can store up to 75 patterns. Each pattern contains one or more fields. A field defines a single object and how it will be printed. Fields may define text strings, Goto commands, or Pause commands. Text fields may include alphanumeric characters, symbols, and special message flags. The message flags automatically insert data into the text string, such as serial numbers, times, and dates.

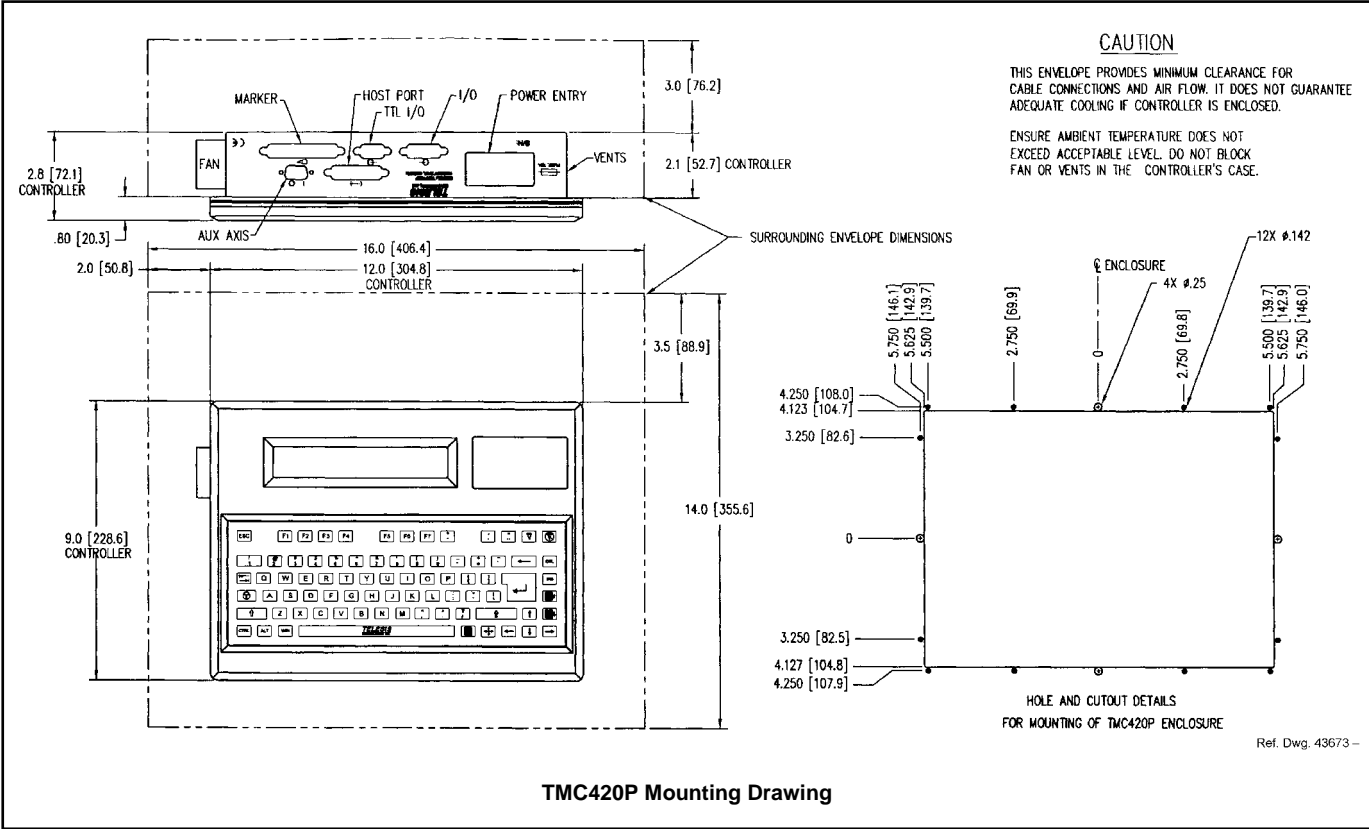
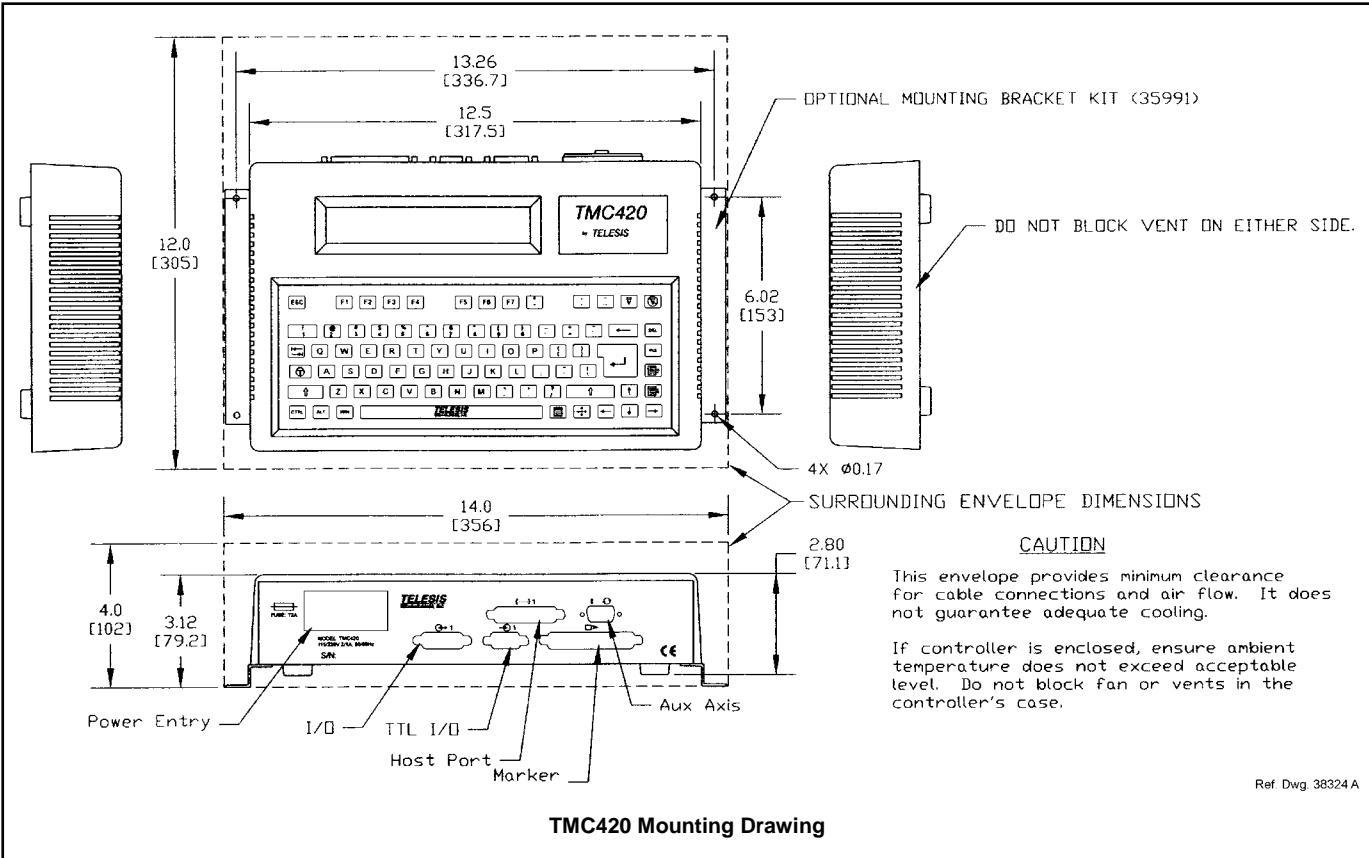

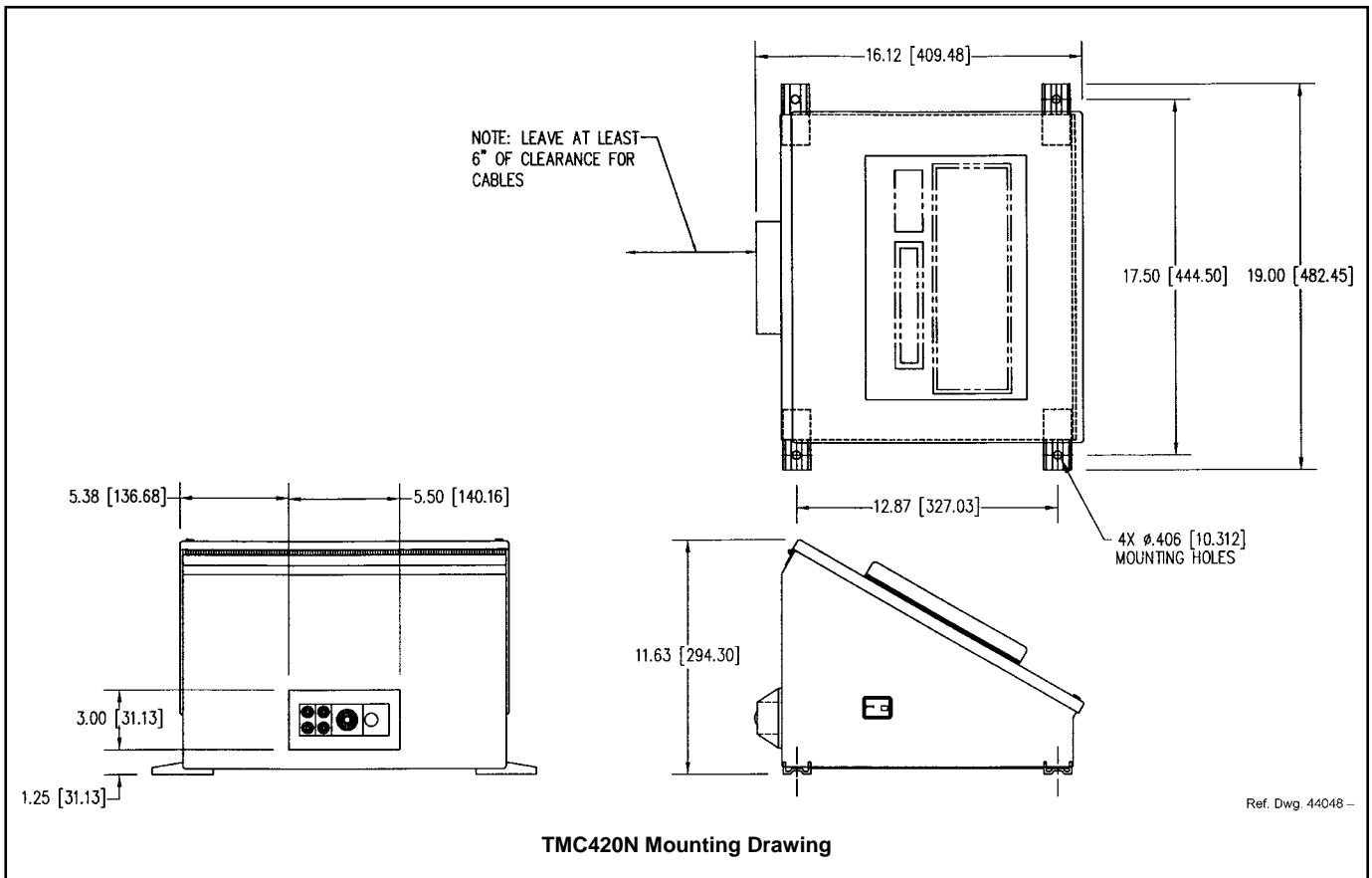

I/O Control Signals. The TMC420 is configured for DC I/O only. The TTL I/O Port may be used to connect a remote pushbutton control for Start Print and Abort commands. The I/O Port may be used to connect a PLC or other DC I/O source. The I/O Port allows remote control of pattern selection, printing, aborting, placing the marker online, and monitoring of the Ready and Done output signals. Cable connectors and connector pins are supplied with the controller for constructing appropriate interface cables.

START PRINT	Input signal, begins print cycle
SEL_0, 1, 2, 3 *	Input signals, remote pattern selection (15* max.)
SEL_3 *	Input signal, marker online
ABORT	Input signal, aborts print cycle
INPUT COMM	For all inputs (+ or – supply)
READY	Output signal, ready for message or start print
DONE	Output signal, print cycle complete
OUTPUT COMM	For all outputs (+ or – supply)

* System software allows SEL_3 signal to be configured for remotely selecting patterns or for remotely placing the marker online. If used for marker online, pattern selection is reduced to 7 patterns (max).

Serial Interface. The Host Port is used for RS-232 and RS-485 communications with serial devices such as a host computer or bar code scanner. Up to 31 controllers may be used in a multi-drop configuration using the RS-485 interface. The host computer can load patterns, download messages, place the marker on/offline, and monitor system errors. (See *Serial Communications* for details.)

Serial Communications. The Host Port may be used for either RS-232 or RS-485 communication. The RS-232 interface is most often used with remote devices such as bar code readers or host computers. The RS-485 interface is normally used for long transmission distances or multi-drop networks of up to 31 TMC420 controllers. The serial port may be configured to communicate using either the Telesis Programmable Protocol or Telesis Extended Protocol. The following describes the serial data character format on all transmissions to and from the TMC420 controller.

- Asynchronous
- 1200, 2400, 4800, 9600, or 19200 baud-host
- One Start Bit
- One or Two Stop Bit(s)
- Seven or Eight Data Bits
- None, Even or Odd Parity

Programmable Protocol is used where very simple one-way communications are required (such as with bar code scanners). Programmable Protocol provides no error checking or acknowledgment of the transmitted data. Note that XON/XOFF Protocol applies even when Programmable Protocol is selected.

Starting Character specifies where the software begins to count character positions. This number must be entered in ASCII decimal format such as 2 for STX.

Terminating Character identifies the end of transmitted string (usually ASCII carriage return character, decimal 13).

Character Position counted from the starting character ignoring all characters preceding it.

Character Length accepts variable length messages (if set to 0) or messages of a pre-specified, fixed number of characters.

Ignore Character identifies the character to ignore when sent from the host (usually ASCII line feed character, decimal 10).

Message Type allows message-type recognition which defines how the marking system will use data it receives from the host..

P loads a specific pattern identified by data extracted from host

V updates first variable text field with data extracted from host

1 overwrites first text field with data extracted from the host

Q updates text in first query buffer with data extracted from host

0 indicates that host will provide message type, field number (if applicable), and data; delegates message type selection to the host on message-by-message basis. The host message must use the format **Tnn<string>** where:

T = P, V, 1, or Q to indicate the message type.

nn = two-digit number to indicate field number or query text buffer where data will be placed. Note that a number is not used with Message Type P.

<string> = pattern name (Message Type P) or field data (Message Types V, 1, or Q), as applicable.

Extended Protocol includes error checking and transmission acknowledgment. It should be used in applications where serial communication is a vital part of the marking operation. Extended Protocol must be used in multi-drop applications. All communications are carried out in a master-slave relationship with the host being the master. Only the master has the ability to initiate communications. If the host does not receive a response within three seconds, it should re-transmit its original message. If no response is received after three tries, it should declare the link to be down.

The following describes the message format as sent from the master to the TMC420 controller.

SOH TYPE [##] STX [DATA TEXT] ETX BCC CR

SOH ASCII Start of Header character (001H). The controller ignores all characters received prior to the SOH.

TYPE A single, printable ASCII character that defines the meaning (type) and content of the message downloaded from the host, where:

- 1** overwrites the specified field of currently loaded pattern, using the format **1nn<string>** where nn is the field number.
- V** updates specified variable text field of currently loaded pattern, using the format **Vnn<string>** where nn is the field number.
- Q** updates specified query buffer with the data received from host, using the format **Qnn<string>** where nn is the buffer number.
- P** specifies pattern name to be loaded for printing
- O** resets marker and places it online
- G** initiates a print cycle to mark the currently loaded pattern
- I** requests the marker output status; returns a single-digit hexadecimal value to report state of READY and DONE:

Returned Value	DONE	READY
0	off	Off
1	off	ON
2	ON	Off
3	ON	ON

- S** requests the marker error status; returns a value that represents a particular type of error:

Returned Value	TYPE OF ERROR
0x0000	(no error)
0x0001	ONLINE_ERROR
0x0002	PATTERN_LOAD_ERROR
0x0004	DISALLOWED_NO_PATTERN
0x0008	DISALLOWED_OFFLINE
0x0010	PATTERN_FIELD_ERROR
0x0020	MARKER_ABORTED_ERROR
0x0080	PIX_OUT_OF_RANGE_ERROR
0x0100	RAM_ERROR
0x0200	SN_RANGE_ERROR

[##] Two optional ASCII decimal digits that specify the Station ID number for use in multi-drop network applications. The ID may range from 00-31. Note that "00" is reserved for applications where only one controller is used. In such applications, this field may be eliminated and "00" will be assumed.

STX ASCII Start of Text Character (002H).

[DATA TEXT] Optional field that may be required for certain message types.

ETX ASCII end of text character (003H).

BCC Optional Block Check Code that is generated and sent to improve link reliability by providing fault detection. The BCC is calculated by taking an eight bit addition of the TYPE and DATA TEXT characters and transmitting them as a three digit ASCII decimal number in the range from 000 to 255. If the sum is greater than 255, the most significant bit overflows and is discarded.

CR ASCII Carriage Return Character (00DH).