

System Overview

The TMP6100/090 marking system permanently prints messages into a variety of materials such as steel, aluminum, and plastic. A hardened pin is pneumatically accelerated to indent dot matrix characters into the item being marked. The shape, size, density, and location of characters are determined by the user through the system software. The marking head moves the pin cartridge through X- and Y-axis motions to reach the correct position for each dot of the characters to be marked. The system software automatically controls pin extension and retraction to mark the message.

TMP6100 Marking Head includes the mechanical motion components to position the marking pin at precise X/Y positions and the pneumatic components to drive the marking pin from, and return the pin to, the pin cartridge.

The TMP6100 marking head is an X- and Y-robotic mechanism which uses stepper motors to independently drive its A- and B-arms. This design provides a generous 12 x 6 in. (304 x 152 mm) marking window. The marking head moves the pin cartridge through the required polar rotation motions to reach the correct position for each dot. It accurately and rapidly positions the pin cartridge at coordinate-defined locations within .002 in. (0.05 mm) of any point in the window.

The floating pin design permits high quality, consistent marks on irregular, slightly curved surfaces. It also accommodates applications where marking surfaces cannot be positioned at a consistent distance from the marker.

Marker Cable connects the marking head to the controller. The highly flexible cable is 4m (13 ft.) long. Optional extension cables are available for greater distances.

Pin Cartridges, machined from plastic materials, offer long life with little maintenance. Clasps are used to attach the pin cartridge to the marking head for easy cleaning and pin replacement.

Marking Pins for the TMP6100 include the 25L-, 25XL-, 101-, and 150S-series. Refer to the marking head installation drawing for pin stroke (pin extension) dimensions. Refer to the marking depth tables for pin cone angles and depths.

Filter/Regulator Unit includes two regulators with pressure gauges to control the drive air and return air. The first regulator contains a filter to help remove contaminants from the supply air. Two air lines connect the regulated air to the marking head. Drive air fires the impact pin; return air pushes it back into the cartridge. The standard air lines are 12 ft. (3.6 m) long made of 1/4" tubing.

Merlin®II Visual Design Software provides a 32-bit graphical user interface to design pattern files and to operate the marker. Merlin®II requires a PC with at least Windows®98, 2000, Me, or XP operating system and one available USB port. To take advantage of the Merlin®II RS-232 or TCP/IP capabilities, the PC must also have one such port available for the host interface.

TMC090 Controller connects to the PC through a USB interface. The PC runs the marking system software and generates commands to control the marker. Commands are passed from the PC through the USB interface to the controller, then on to the marking head and its optional equipment.

System Options

- Mounting Post with Hand Crank (19.3" [492mm] travel)
- Marking Head Extension Cables
- Theta Axis with Programmable Rotary Drive Fixture
- Z Axis Mounting Post with Programmable Vertical Travel
- Bar Code Scanner or Bar Code Wand with Cable
- Foot Switch (Start Print) or Pushbutton Station (Start/Abort)
- Logo/Font Generator Software

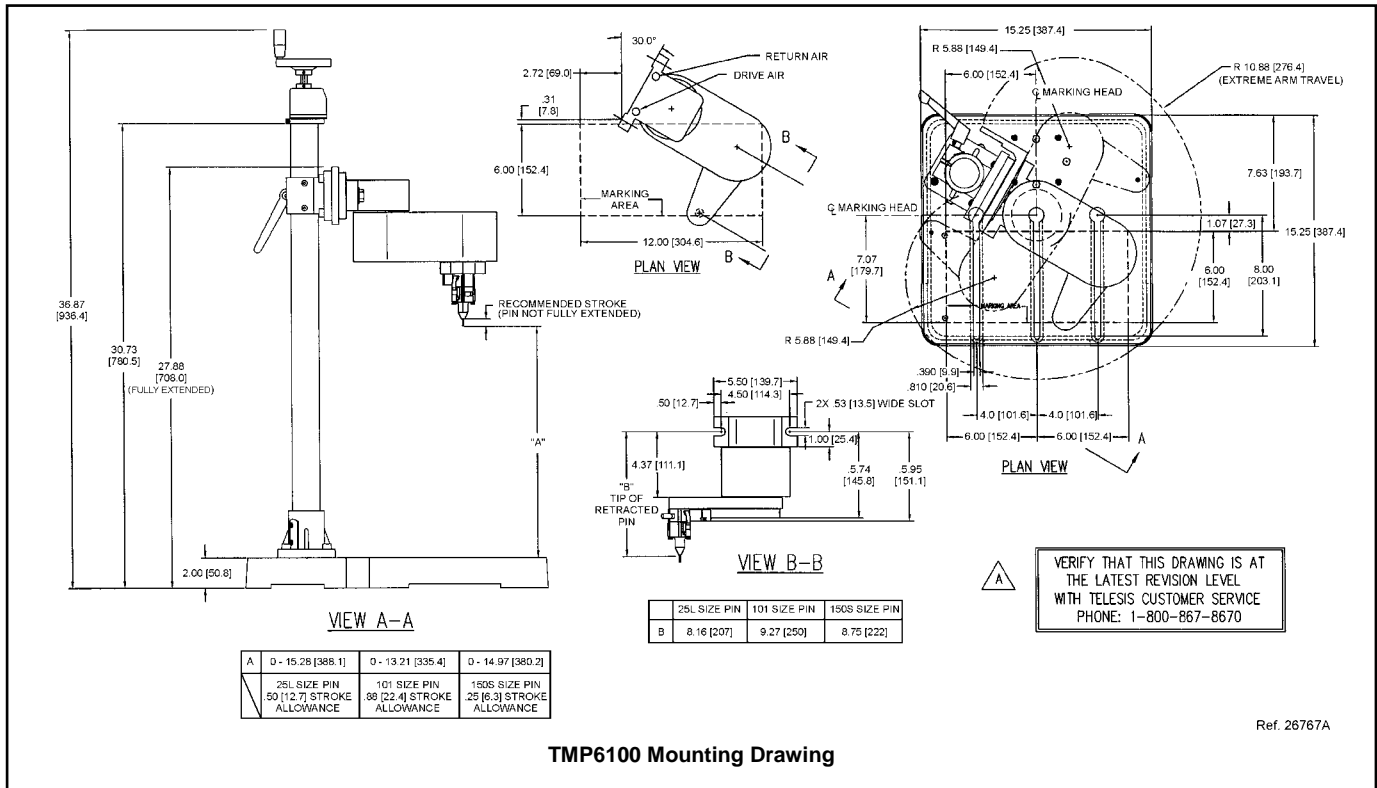

TMP6100 Mounting Drawing

System Setup

When designing a fixture, allow for 3-axis adjustment to aid in horizontal, vertical, and lateral alignment of the marking head.

1. Mount marking head using two ½-13 bolts.
2. Mount filter/regulator assembly within 12 ft. (3.6m) of marker.
3. Connect drive air and return air lines to the marking head.
4. Connect supply air to input port on filter/regulator assembly.
5. **The TMC090 is not a sealed unit. Protect it from potentially damaging conditions; do not block case vents.** Locate controller as close as practical to marking head. Standard marker cable length is 4m (13 ft.).
6. Ensure controller and PC power switches are OFF.
7. Connect USB cable to controller and to PC.
8. Connect marker cable to marking head and to controller.
9. Connect power cables to controller and to PC.
10. Position PC power switch to ON.
11. For customer-supplied PC, install marking system software.
12. Position controller power switch to ON.
13. Start marking system software.
14. Adjust pin stroke, drive air, and return air for impact depth.

TMP6100 Marking Head Specifications

- DIMENSIONS** *see illustration above*
- WEIGHT** 16.8 lb. (7.6 kg) not including support tooling
- OPERATING TEMP.** 32° to 122° F (0° to 50° C), non-condensing
- AIR SUPPLY** Clean and dry, 60 to 120 psi (4.2 to 8.3 bars)
- AIR CONSUMPTION** .3 SCFM (idle) 1.5 SCFM (marking)
- MARKING AREA** 12.0 x 6.0" (304 x 152 mm)
- PIN TYPES** 25L-, 25XL-, 101-, or 150S-series
- PIN MATERIAL** Powdered metal or carbide (25L-, 25XL-, 101-series)
Powdered metal or carbide-tipped (150S-series)

Marking Characteristics. The TMP6100 can produce characters as small as .060" (1.5mm), printed at any angle within the marking window. Printing resolutions range from 10 dots per inch to 200 dots per inch for an engraved look. The depth of mark can be adjusted over a significant range by adjusting the pin stroke and, to a lesser extent, by adjusting the drive air pressure.

Marking Speeds. Generally, the system will mark two characters per second (using 5x7 font, .125" [3 mm] high characters). Speeds will vary slightly depending on the selected character size, style, and dot density. Specific times can be verified by a Telesis representative.

Marking Noise. Although every attempt is made to reduce noise, the material being marked significantly influences the noise level. For example, marking a solid lead block produces less noise than marking a thin-walled steel pipe.

TMP6100 Marking Head Specifications (continued)

Pin Life. Pin life depends largely on the type of material being marked, how hard or abrasive it is, and the required marking depth. On typical metals with a hardness of Rockwell Rb47, marking at a depth of .005" (.127 mm), powdered steel pins average about 3 million impressions before needing sharpened; carbide pins average approximately 9 million impressions. If carbide pins are used, marking times will increase by approximately 25% due to the increased weight of the pins.

Marking Depth. The following tables provide sample marking depths. Drive air was set at 80 psi (5.5 bars); return air was set at 20 psi (1.4 bars); pin stroke was set to the maximum allowable distance for each pin type to achieve the maximum depth of mark.

Max. Marking Depths – Type 25L Powdered-Metal Pin

MATERIAL (HARDNESS)	22° CONE	30° CONE	45° CONE	60° CONE
Aluminum (Rb2)	.003 in .076 mm	.005 in .127 mm	.007 in .178 mm	.008 in .203 mm
Brass (Rb22)	.0025 in .0635 mm	.003 in .076 mm	.0055 in .1397 mm	.008 in .203 mm
Cast Iron (Rb47)	.002 in .051 mm	.003 in .076 mm	.0055 in .1397 mm	.007 in .178 mm
Cold Rolled Steel (Rb53)	.0025 in .0635 mm	.003 in .076 mm	.004 in .102 mm	.006 in .152 mm

Max. Marking Depths – Type 25L Carbide Pin

MATERIAL (HARDNESS)	22° CONE	30° CONE	45° CONE	60° CONE
Aluminum (Rb2)	.004 in .102 mm	.005 in .127 mm	.008 in .203 mm	.008 in .203 mm
Brass (Rb22)	.0025 in .0635 mm	.004 in .0889 mm	.007 in .178 mm	.008 in .203 mm
Cast Iron (Rb47)	.0025 in .0635 mm	.004 in .102 mm	.007 in .178 mm	.008 in .203 mm
Cold Rolled Steel (Rb53)	.0025 in .0635 mm	.0035 in .0889 mm	.006 in .152 mm	.007 in .178 mm

Max. Marking Depths – Type 150S Pin

MATERIAL (HARDNESS)	22° CONE	30° CONE	45° CONE	60° CONE
Aluminum (Rb2)	N/A	.006 in .152 mm	.008 in .203 mm	.012 in .305 mm
Brass (Rb22)	N/A	.005 in .127 mm	.012 in .305 mm	.011 in .279 mm
Cast Iron (Rb47)	N/A	.005 in .127 mm	.010 in .254 mm	.010 in .254 mm
Cold Rolled Steel (Rb53)	N/A	.0045 in .1143 mm	.006 in .152 mm	.009 in .229 mm

TMC090 Controller Specifications

DIMENSIONS	<i>refer to TMC090 Mounting Drawing</i>
RATING	NEMA 1 (I.P. 30)
WEIGHT	4.75 lb. (2.15 kg)
OPERATING TEMP.	32° to 122° F (0° to 50°C), non-condensing
REQUIRED POWER	95-130 VAC, 2 amps, 50-60 Hz single phase 200-250 VAC, 1 amp, 50-60 Hz single phase
I/O VOLTAGE	12 to 24 VDC (customer-supplied)

Merlin®II Visual Design Software. The marking system software runs on a PC and connects to the controller via the USB port. It provides the interface for operating the marker. The software is an easy-to-use, graphical-design application that provides tools for creating, saving, loading, and editing user-defined patterns. Each pattern contains one or more fields; each field defines a single object. Printable objects may be created to define text strings, arc-text strings, geometric shapes, graphics, and machine-readable data matrix symbols. Non-printable objects may be defined to specific commands to the marker (e.g., Pause, Go to, Input, or Output). Printable text fields may include alphanumeric characters, symbols, and special message flags. Message flags automatically insert data into the text string, such as serial numbers, times, dates and user-defined codes.

Interface Panel. The interface panel provides various ports for connecting the controller to the marking system equipment. The Marker port, USB port, and Aux Axis port are used to connect the marking head, system PC, and optional auxiliary axes, respectively.

I/O control signals may be connected to the I/O port and the TTL Input port. (See *I/O Control Signals*.) RS-232 and TCP/IP communications may be connected to the PC and routed to the marker through the USB port. (See *Host Communications*.)

I/O Control Signals.

The TMC090 is configured for DC I/O only.

The TTL Input port may be used to connect a remote push button control for sending Start Print and Abort commands to the marker.

The I/O port may be used to connect a PLC or other DC I/O source. The I/O port allows remote control of printing, aborting, placing the marker online, and monitoring of the Ready and Done output signals. Additionally, the I/O port allows for remote pattern selection. The marking system can monitor four separate input signals and, based on the on/off state of those signals, will select and open a specific pattern stored on the PC.

Cable connectors and connector pins are supplied with the controller for constructing appropriate interface cables.

START PRINT	Input signal: begin print cycle
SEL_0, 1, 2, 3	Input signals: pattern selection; marker online
ABORT	Input signal: abort print cycle
INPUT COMM	For all inputs (+ or – supply)
READY	Output signal: ready for message or start print
DONE	Output signal: print cycle complete
OUTPUT COMM	For all outputs (+ or – supply)

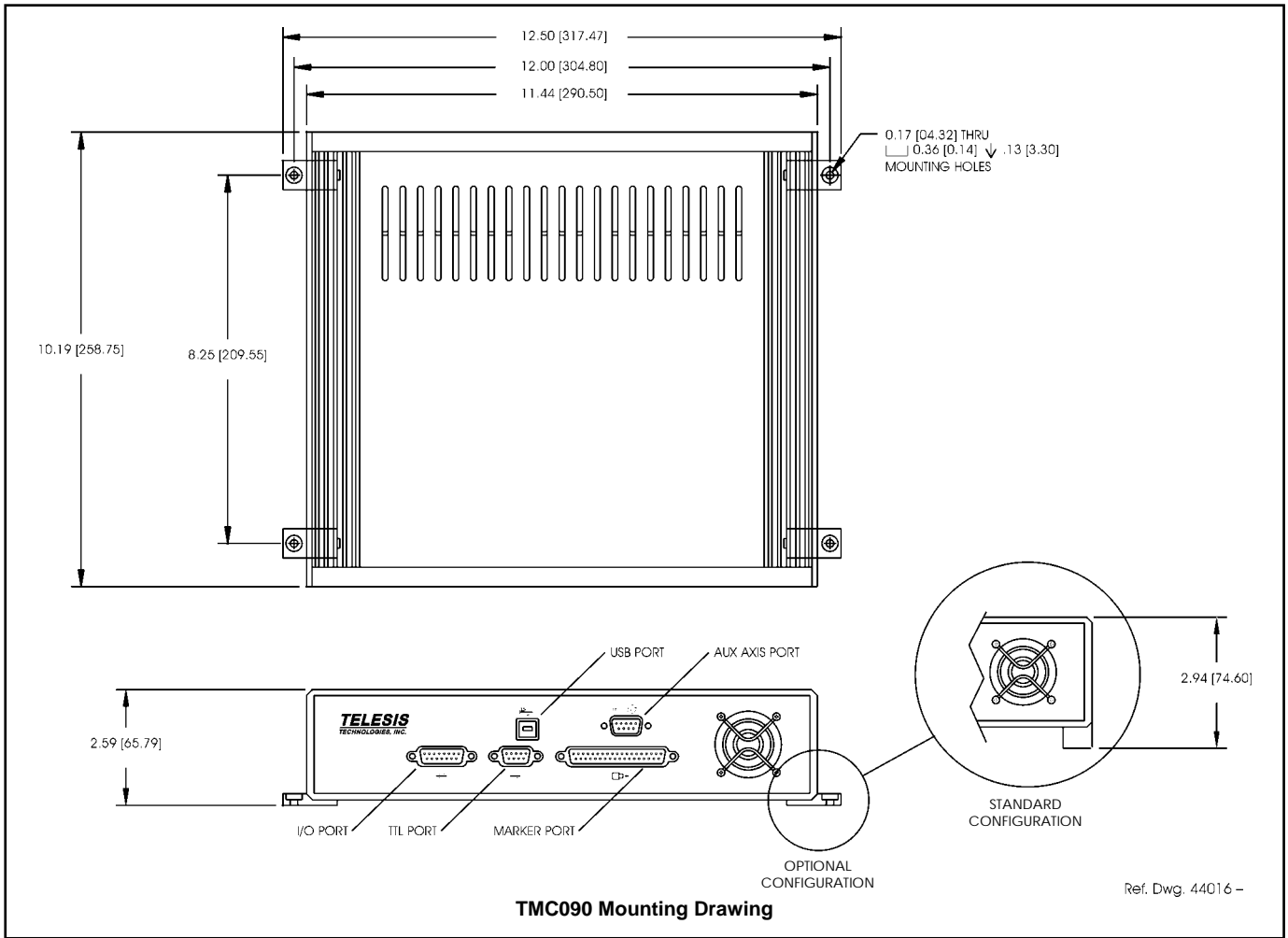

Host Communications

The marking system software allows you to configure communication parameters to transmit and receive data to and from a host computer or a remote I/O device. The host communicates with the marking system software via the host interface on the system PC. The software passes information to and from the marking equipment via the controller USB interface. To provide maximum integration flexibility, the system software supports Ethernet (TCP/IP) interfaces and serial (RS-232) interfaces. It also provides two protocol choices: Programmable Protocol and Extended Protocol.

TCP/IP Interface. The Ethernet (TCP/IP) interface is most often used with host computers communicating over a local area network (LAN). With this type of interface, you may use either Extended Protocol or Programmable Protocol.

The Port parameter identifies the host computer socket that is assigned to the marking system. If more than one marking system is installed in a network configuration, each system must use a separate and unique port number. The Address parameter identifies the IP (Internet Protocol) address of the host computer. The marking system software supports both fixed addressing and dynamic addressing.

RS-232 Interface. The serial (RS-232) communications interface is most often used with remote devices such as host computers, terminals, or bar code scanners. The RS-232 interface supports both Extended Protocol and Programmable Protocol.

If more than one controller is connected to the host, you must identify each controller with a unique station identifier. The station ID is sent at the beginning of a message, so only the marker with that ID number receives the message. However, in order to use multiple-marker communications, you must use an interface that will support multi-drop communications (e.g., RS-485).

The following describes the serial data character format on all transmissions to and from the TMC090 controller.

- Asynchronous
- 300, 600, 1200, 2400, 4800, 9600, 19200, 38400, 57600, or 115200 Baud
- 1, 1.5, or 2 Stop Bits
- 5, 6, 7, or 8 Data Bits
- None, Even or Odd Parity

Programmable Protocol. Use this protocol where very simple one-way communications are required (such as with bar code scanners). Programmable Protocol provides no error checking or acknowledgment of the transmitted data. Note that XON/XOFF Protocol applies even when Programmable Protocol is selected.

Starting Character specifies where the software begins to count character positions. This number must be entered in ASCII decimal format such as 2 for STX.

Terminating Character identifies the end of transmitted string (usually ASCII carriage return character, decimal 13).

Character Position counted from the starting character ignoring all characters preceding it.

Character Length accepts variable length messages (if set to 0) or messages of a pre-specified, fixed number of characters.

Ignore Character identifies the character to ignore when sent from the host (usually ASCII line feed character, decimal 10).

Message Type allows message-type recognition which defines how the marking system will use data it receives from the host.

49 (Type 1) overwrites first text field with data extracted from the host

80 (Type P) loads a specific pattern identified by data extracted from host

81 (Type Q) updates text in first query buffer with data extracted from host

86 (Type V) updates first variable text field with data extracted from host

0 (Type Zero) indicates that host will provide message type, field number (if applicable), and data; delegates message type selection to the host on message-by-message basis. The host message must use the format **Tnn<string>** where:

T = 1, P, Q, or V to indicate the message type.

nn = two-digit number to indicate field number or query text buffer where data will be placed. Note that a number is not used with Message Type P.

<string> = field data (Message Types 1, Q, or V) or pattern name (Message Type P), as applicable.

Extended Protocol. This protocol selection includes error checking and transmission acknowledgment. It should be used in applications where serial communication is a vital part of the marking operation. All communications are carried out in a parent/child relationship with the host being the parent. Only the host has the ability to initiate communications. If the host does not receive a response within three seconds, it should re-transmit its original message. If no response is received after three tries, it should declare the link to be down.

The following describes the Extended Protocol message format as sent from the host to the TMC090 controller.

SOH TYPE [##] STX [DATA TEXT] ETX BCC CR

SOH ASCII Start of Header character (001H). The controller ignores all characters received prior to the SOH.

TYPE A single, printable ASCII character that defines the meaning (type) and content of the message downloaded from the host, where:

- 1** overwrites specified field of currently loaded pattern, using the data format **nn<string>** where nn is the field number.
- P** specifies pattern name to be loaded for printing
- Q** updates specified query buffer with data received from host, using the data format **nn<string>** where nn is the buffer number.
- V** updates specified variable text field of currently loaded pattern, using the data format **nn<string>** where nn is the field number.
- O** resets marker and places it online
- G** initiates a print cycle to mark the currently loaded pattern
- I** requests the marker return the status of standard output and input signals in the hexadecimal format: **O₂ O₁ ; I₂ I₁**
The first digit of the hexadecimal code reports the signal states of output signals Spare-3 and Spare-2. The second digit reports the states of output signals Spare-1, Spare-0, Pause, Ready, and Done.
The third digit reports the signals states of input signals Select-4 and Select-3. The fourth digit reports the state of input signals Select-2, Select-1, Abort, and Go.

[##] Two optional ASCII decimal digits that specify the Station ID number for use in multi-drop network applications. The ID may range from 00-31. Note that "00" is reserved for applications where only one controller is used. In such applications, this field may be eliminated and "00" will be assumed.

STX ASCII Start of Text Character (002H).

[DATA TEXT] Optional character string that may be required for certain message types (e.g., Type 1, P, Q, and V).

ETX ASCII end of text character (003H).

BCC Optional Block Check Code that is generated and sent to improve link reliability by providing fault detection. The BCC is calculated by taking an eight bit addition of the TYPE and DATA TEXT characters and transmitting them as a three digit ASCII decimal number in the range from 000 to 255. If the sum is greater than 255, the most significant bit overflows and is discarded.

CR ASCII Carriage Return Character (00DH).